



KUSTER COMPANY

FLOW THROUGH SAMPLER (FTS)

OPERATING INSTRUCTIONS

Kuster Company, division of F.T.I. Inc.
2900 E. 29th Street · Long Beach, CA 90806-2315
Tel: 562-595-0661 · Fax: 562-426-7897
kuster@kusterco.com
www.kusterco.com

CONTENTS:

1. SPECIFICATIONS	3
2. DESCRIPTION	4
3. OPERATION INSTRUCTION	4
4. APPLICATION NOTES	5
5. SAMPLE TRANSFER	6
6. MAINTANANCE	6
7. PARTS LIST	9
8. DRAWINGS: LATCHING MECHANISM AND VALVES	10
9. MAINTENANCE OF HP SAMPLER CLOCK	13

1. SPECIFICATIONS

Capacity	600 cc
Maximum Temperature	232C (450F)
Maximum Pressure	680 kg/sq cm (10,000 psi)
Length	221 cm (87 in)
Diameter	38 mm
Seal Material	Viton
Material	17-4 PH SS, Monel
PH	2.9-9.0
Salinity	0-300,000 ppm
Transfer Method	Mercury Equilibrium Type
Clocks	Programmable for 1, 1.5 and 6 hours

SUPPLIES AND ACCESSORIES

Item	Part Number
Field Kit	11700-300
Shipping Bottle 600 cc	11560-102
Transfer Apparatus-Mercury Type	11580-201

2. DESCRIPTION

The Kuster Flow Through Sampler FTS is a device for obtaining fluid samples from a producing well. The sample chamber is lowered into the well with open valves on each end, allowing well fluids to pass freely through the chamber. At a time programmed on the surface, the valves close, trapping the fluid. The sampler can then be removed from the well. The sample contained in the chamber will remain in the same state as it was in the well. The pressure will not be changed. The sample can then be removed from the sampler and transferred to a container suitable for storage by means of transfer apparatus. The transfer can be made without changing the pressure on the sample or contamination it.

The instrument consists of a sample chamber with a spring-loaded valve on each end. A latching mechanism connects the valves together and holds them open. Above the chamber there is a clock to program the closing time, and a ball operated tripping mechanism to release the valves. The lower end has a removable bull nose with ports to allow the fluid to enter. At the top there is a rope socket for attaching the wire line.

3. OPERATION INSTRUCTION

A. Remove the following components:

- Bull nose
- Clock housing

B. Open the valves

The valves now need to be opened and latched. To accomplish this first the valve on the lower end needs to be opened and held there while the upper valve is opened. It is important that the lower valve is opened first or the latching mechanism between the valves will not function. This is easily done with two people, however, if a second person is not available to help it can be done by threading a transfer Head Assembly (11728-100) on the lower end of the sampler and rotating the handle all the way to the right. Now the upper valve is opened by placing a small diameter tool (4mm or less) in the small hole at the end of the 3-hole Sleeve (11710-001) and applying enough pressure to overcome the valve spring. When the valve is completely open, the Slip (11731-001) will move upward, latching the valve open. It may be necessary to rotate the Slip slightly to get it to latch. If the lower valve was held opened by another person, it can now be released. If the Transfer Head Assembly was used, the handle can be rotated to the left until it stops. The head can now be removed. To verify the valves are open, look at the springs. They will be near total compression if they are open.

It is recommended that the valves be latched and released several times to gain a familiarity with the instrument and to check that they are functioning correctly. To release the valves, simply move the Slip toward the bottom. Both valves can be observed while they are closing.

REMEMBER: THE LOWER VALVE MUST BE OPENED FIRST

C. Program the Clock

Set the valve closing time pressing the time drum toward the frame and then rotating it until the desired time on the drum is aligned with the mark on the frame. Any time period up to the maximum time of the clock can be selected. If an intermediated time period is chosen, be careful not to go too far. The time drum cannot be rotated backwards. Now, to make sure the clock is running, place it to your ear.

Place the clock in the Clock Housing (11537-011), time drum toward the bottom. Place O-ring (706-075) on the top of the clock. If a maximum registering thermometer is to be used, thread the Thermometer Well (11719-001 optional) on top of the Clock Housing. If a thermometer is not going to be used, the Top Cap (11529-011) can be installed on the top of the Clock Housing.

D. Install the Thermometer (optional)

Place the Thermometer of the desired temperature range in the Thermometer Well. It is recommended that an O-ring be wrapped around the top and bottom of the Thermometer to protect it from vibration damage. Thread the Top Cap on the Thermometer Well.

E. Install the Bull Nose

The sampler now is ready to be attached to the wire line.

4. APPLICATION NOTES

- Before sampling, determine the temperature and pressure conditions for a proper sampling program.
- Contamination can take place if a subsurface zone is encountered of a pressure greater than the pressure of the contained sample.

5. SAMPLE TRANSFER

For more details see Flow through Sampler Apparatus instruction manual.

The sample can be transferred from the sample chamber of the sampler to a suitable container for shipping while maintaining pressure on the sample at all times.

To facilitate this transfer, a transfer apparatus and (2) Kuster Transfer Head Assemblies (11728-100) for the Flow Through Sampler must be used. The Transfer Apparatus (11580-201) is a mercury displacement device. The Shipping Bottle (11560-102) is filled with mercury and placed in a position higher than the sampler. The Transfer Head Assemblies are attached to the ends of the sampler. On each Transfer Head there are two threaded ports. The port closest to the handle must have a bleed valve installed in it. The other port is for tubing that will connect sampler to the sample bottle. Both Transfer Heads need to be bled to remove trapped air. To accomplish this, the transfer at the top of the sampler needs to be bled first. The sampler then needs to be rotated so the valve that was on the bottom is on the top. Only then can it be bled.

After the Transfer Apparatus is attached and bled, the system must be pressurized to a point that equals the pressure of the sample. The valves on the Transfer Apparatus are opened allowing the mercury to flow to the sampler, in turn forcing the sample into Sample Bottle. After transfer is complete, the valves on the Shipping Bottle must be closed in order to contain the sample.

6. MAINTENANCE

The Kuster Flow Through Sampler (FTS) should require very little maintenance other than a disassembly for cleaning after it had been used and periodic O-ring changes.

The O-ring life is dependent on the temperature at which the tool is used. If temperatures are below 300F (150C) the O-ring life will be significantly increased. If temperatures exceed 300F the O-ring will be harden much sooner. Particular attention needs to be paid to the Viton O-rings on the valves. If these rings get too hard, they will not seal.

Disassembly:

Disassemble the tool by removing the components in the following order:

1. Top Cap (11539-011)
2. Thermometer Well (11719-001 optional)
3. Clock Housing (11537-011)
4. Upper Coupling Assembly (11727-001)
5. Coupling (11723-001)
6. Upper Valve Body Assembly (11700-503)
7. Bull Nose (11718-001)
8. Lower Valve Body Assembly (11700-502)

The Upper and Lower Valve Body Assemblies can be dismantled by pressing on the Spring Cap (11705-001). When compressed, the Split Rings (11705-002) can be removed. The Valves can now be removed from the Valve Bodies for cleaning and inspection. Removing the Circlip (11732-002) at the base of the Valve Guide (11730-001) allows its removal.

To disassemble the Upper Coupling (11727-001), remove the Packing nut (11724-001) and pry out Packing Gland (11721-001) by making use of the small flange of the Packing Gland. After removing the Packing Gland, the Push Rod (11706-001) can be removed. The latch mechanism is disassembled by unthreading the 3-hole Sleeve (11701-001)

Inspection:

1. Check all O-rings for damage or hardening.
2. Check valve sets for scratches. If there are scratches, lightly sand them out with fine sand paper.
3. Clean Push Rod (11706-001). The surface of the Push Rod is hard chrome plated and polished. Consequently, it should never be cleaned with abrasives.
4. Check Push Rod for straightness.
5. Check Valve Springs (11707-001) for tension.
6. Make sure the Lugs (11710-001) on the Latch (11711-001) move freely.
7. The Sleeve (11709-001) at the end of the Upper Valve (11708-001) should be polished.

If the latching mechanism is disassembled, be sure to measure the distance the threaded section of the connection link protrudes through the adjusting nuts. This adjustment set the valve opening distance. The correct distance is .138 inches (3.5 mm).

Assembly

Reverse order of disassembly

The ends of the Sample Chamber (11720-001) are identical. The Valve Body assemblies can be installed on either end. Particular attention must be paid to which Valve Body the Coupling (11723-001) is treaded on. The Coupling must be installed on the Valve Body with the 1/8th inch (3mm) wide groove around the outside diameter through the wrench flats. The Serial Number is also stamped on the wrench flat.

3 Points Need Lubrication

1. The Push Rod (11706-001) and O-rings (706-005), that seal around it.
2. The Balls (730-010) in the latching mechanism.

The above places should be lubed with a good light mineral oil if temperatures are below 300F (150C). If instrument temperatures exceed 300F, then Kuster K-TOX (911-202) should be used.

All threaded connections should be lubed with Kuster Thread Lube (915-001)

7. PARTS LIST

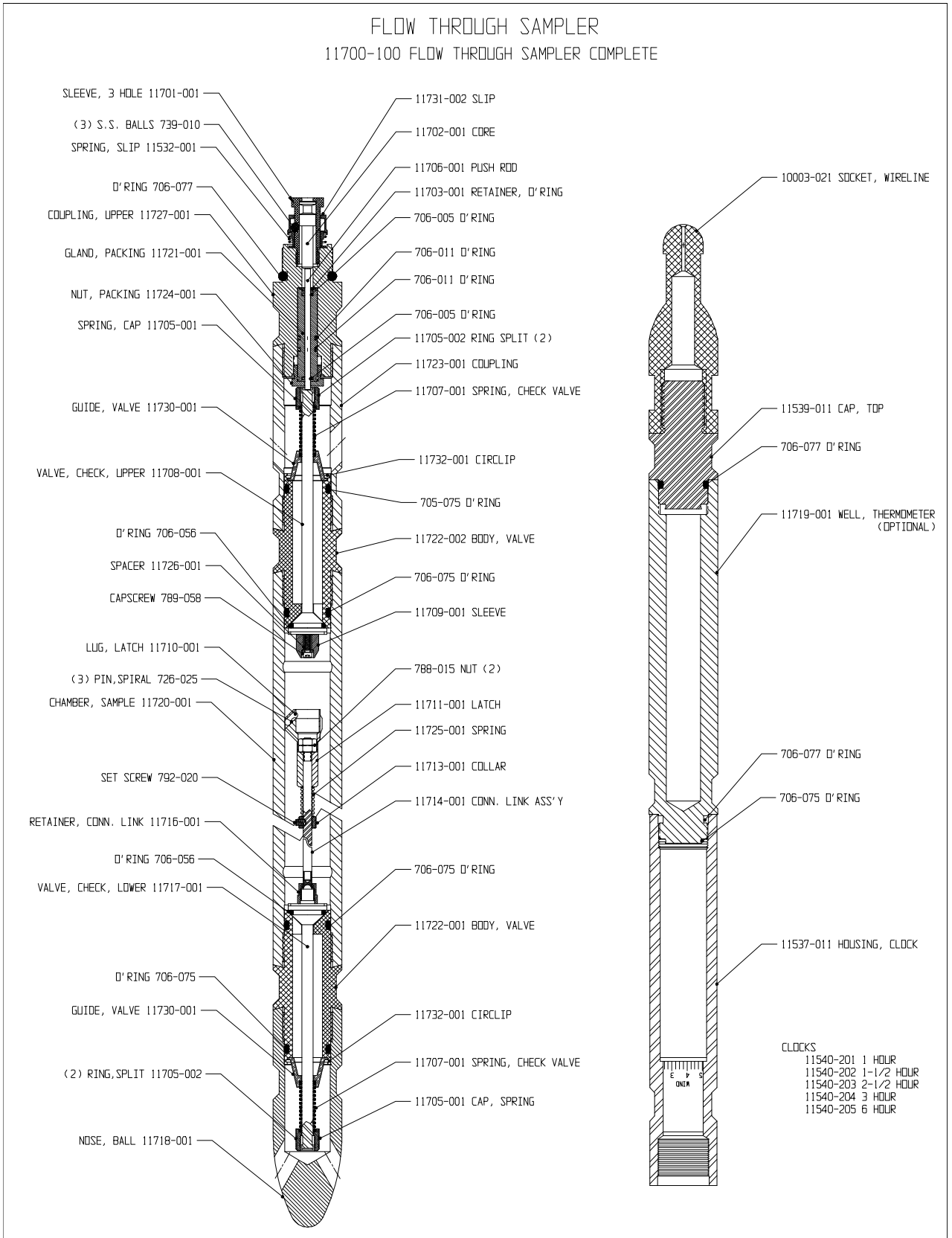

8. DRAWINGS: LATCHING MECHANISM AND VALVES

11700-501	REVISIONS		DATE	APPROVED
		DESCRIPTION		

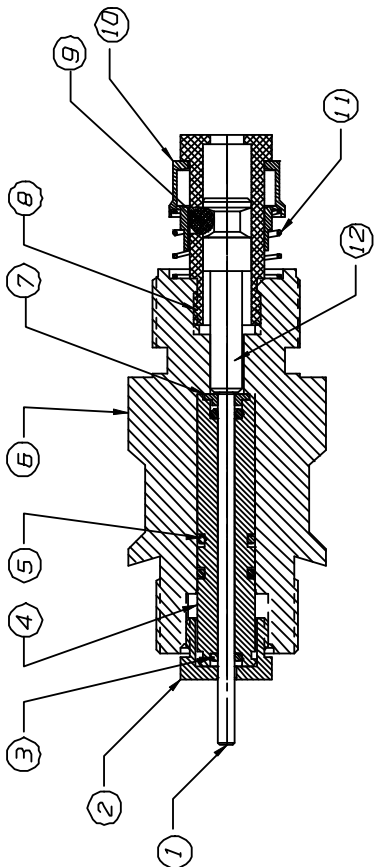
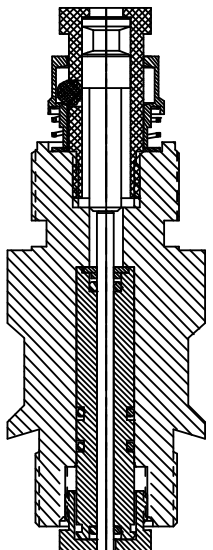
ITEM	PART NUMBER	QTY	DESCRIPTION
1	11706-001	1	PUSH ROD
2	11724-001	1	NUT PACKING
3	706-005	2	O' RING
4	11721-001	1	GLAND PACKING
5	706-011	2	O' RING
6	11727-001	1	UPPER COUPLING
7	11703-001	1	RETAINER
8	11701-001	1	HOLE SLEEVE
9	739-010	3	SS BALL
10	11731-002	1	SLIP
11	11532-001	1	SPRING
12	11702-001	1	CORE

PART DESCRIPTION		UPPER LATCHING MECHANISM	
ASSEMBLY WHERE USED 11700-XXX FLOW THRU SAMPLER			
LINEAL DIM.		TOLERANCES-UNLESS OTHERWISE NOTED	
XXX ±.001	CORNER FILLET	.005	MAX.
XX ±.005	EDGE BREAK	.005	MAX.
FRAC. ±.010	CHAMFERS	45	±5 DEG.
ANGLES	±1 DEG.		
SURFACE FINISH	64 RMS		
CONCENTRIC DIA.	27		

DRAWN	APPROVED	DATE	SCALE
R. WOOD	L.M.K.	93-11-03	NTS
DIMENSIONS PER ANSI Y14-5M			

KUSTER COMPANY	
2900 E. 25TH ST. LONG BEACH, CA.	
SHEET	REV
1 OF 1	NC
FILE NAME	DWG NO.
11700501	11700-501

NOTES:
1. ENGINEERING DATA ON LEVEL 15.

11700-503

REVISIONS

DESCRIPTION	DATE	APPROVED

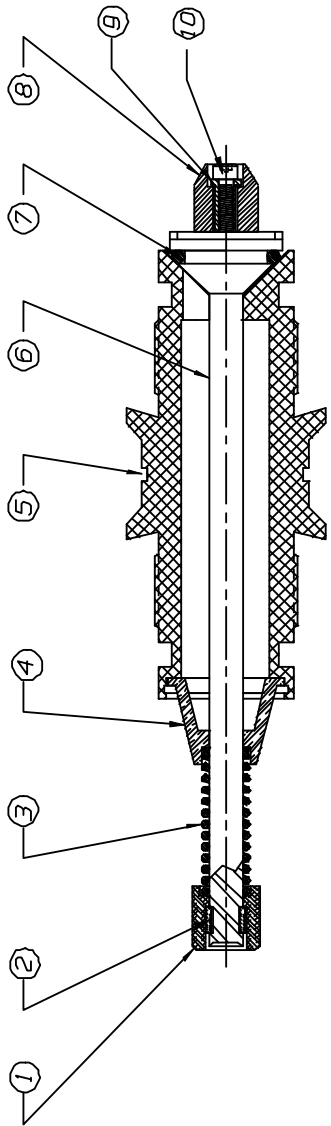

FULLY SEATED

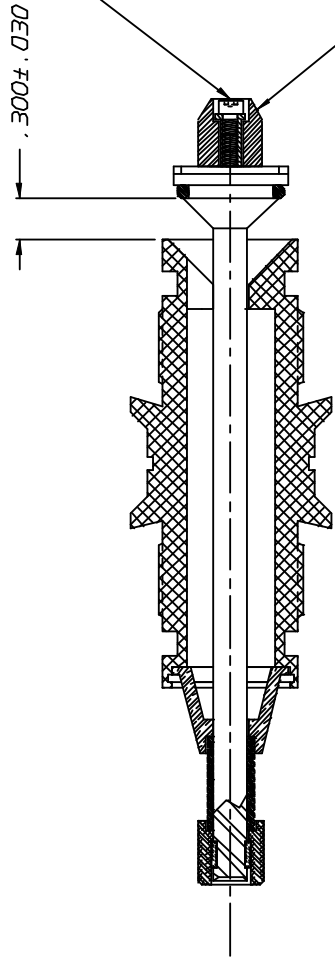

FULLY OPEN

- NOTES:
 1, GROOVE INDICATES THE UPPER VALVE ASSY
 2, ENGINEERING DATA ON LEVEL 15.

ITEM	PART NUMBER	QTY	DESCRIPTION
1	11705-001	1	CAP SPRING
2	11705-002	2	SPLIT RING
3	11707-001	1	SPRING
4	11730-001	1	GUIDE
5	11722-002	1	BODY
6	11708-001	1	UPPER VALVE
7	706-056	1	O' RING
8	11709-001	1	SLEEVE
9	11725-001	1	SPACER
10	789-058	1	CAPSCREW

ASSEMBLY WHERE USED
 11700-XXX
 FLOW-THRU SAMPLER

KUSTER COMPANY
 2900 E. 29TH ST. LONG BEACH, CA.
 SHEET REV FILE NAME
 1 OF 1 NC 11700503
 11700-503

PART DESCRIPTION	TOLERANCES-UNLESS OTHERWISE NOTED
UPPER VALVE ASSY.	XXX $\pm .001$ CORNER FILLET XX $\pm .005$ EDGE BREAK FRAC. $\pm .010$ CHAMFERS +1 DEG. SURFACE FINISH 64 RMS CONCENTRIC DIA. $\pm .001$

DRAWN	APPROVED	DATE
R. WOOD	L/MK	93-11-02
DIMENSIONS PER ANSI Y14-5M		SCALE
		NTS

11700-502

REVISIONS

DESCRIPTION

DATE

APPROVED

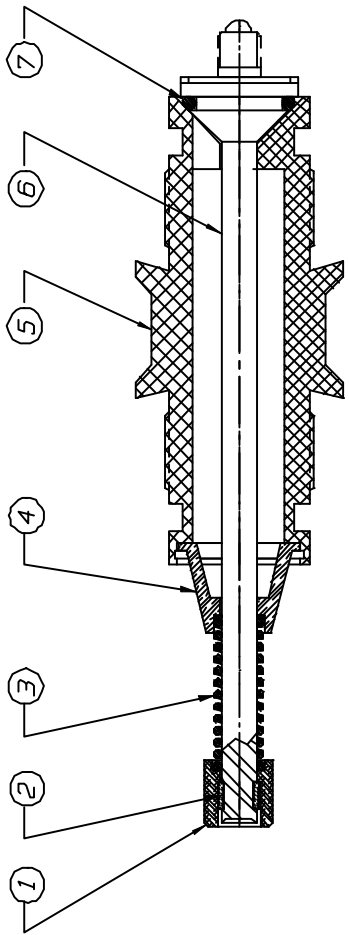

FULLY SEATED

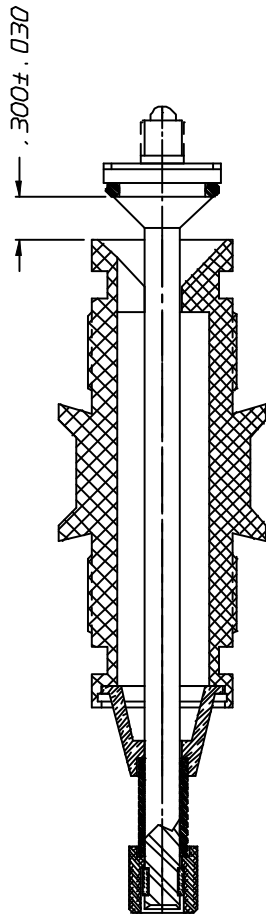

FULLY OPEN

NOTES:
 1. ENGINEERING DATA ON LEVEL 15.
 2. COMPRESSION OF VALVE TO BE

ITEM	PART NUMBER	QTY	DESCRIPTION
1	11705-001	1	SPRING CAP
2	11705-002	2	SPLIT RING
3	11707-001	1	SPRING
4	11730-001	1	GUIDE
5	11722-001	1	BODY
6	11717-001	1	VALVE, LOWER
7	706-056	1	O-RING

ASSEMBLY WHERE USED
 11700-XXX

FLOW-THRU SAMPLER

KUSTER COMPANY
 2900 E. 29TH ST. LONG BEACH, CA.

SHEET 1 OF 1
 REV NC
 FILE NAME 11700502
 DWG NO. 11700-502

PART DESCRIPTION

LOWER VALVE ASSY.

TOLERANCES-UNLESS OTHERWISE NOTED

LINEAL DIM. .005 MAX.
 .005 MAX.
 45 ±5 DEG.

XXX ±.001
 XX ±.005
 FRAC. ±.010
 ±1 DEG.
 64 RMS

CORNER FILLET
 EDGE BREAK
 CHAMFERS

ANGLES
 SURFACE FINISH
 CONCENTRIC DIA.

DATE 93-11-03
 SCALE NTS

DRAWN R. WOOD
 APPROVED LMK
 DIMENSIONS PER ANSI Y14-5M

9. MAINTENANCE OF HP SAMPLER CLOCK

The Time Drum Assembly and the Barrel Cap require frequent attention and cleaning. A print has been included with this maintenance sheet for reference.

Servicing Procedure:

1. Remove the Lock nut from the arbor. This should be done with the clock run down and the Time Drum in the Up position.
2. Remove the Time Drum from the Arbor. It should slide off easily. Be careful of the bearing in the arbor bushing, as it is loosely mounted in this part.
3. Inspect the Barrel Cap. This part should be free of any foreign matter and have a smooth surface. It has a nickel plating to make the surface smooth and inhibit damage to the finish from the well environment. Wipe the Barrel Cap clean and apply a thin coating of high temperature grease paying close attention the underside where the bearing /pin assembly rides.
4. Inspect the Time Drum. This part should be clean and free of any foreign material. Make sure the Bearing that goes in the Arbor Bushing spins freely. Clean the Bearing/Pin Assembly. The Bearing Sleeve should turn freely. If this part is damaged it must be replaced. To replace this assembly use a pin or drill smaller than 1/8". Press the assembly inward into the Time Drum. Press the new bearing assembly in the same way. Again make sure the Bearing Sleeve turns freely. Apply a thin coat of high temperature grease to this part.
5. Inspect the Arbor. Wipe it clean and add a thin coat of high temp grease. Place the Time Drum onto the Arbor – don't forget the Bearing in the Arbor Bushing. It should slide freely up and down on the arbor.
6. Replace the Lock Nut. Hold the Time Drum and screw the nut down using a nut driver.

