

# Air Calibration Bath

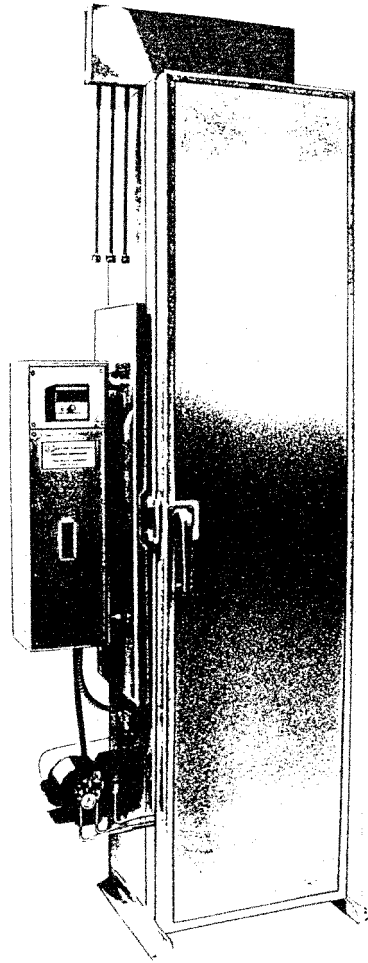

2900 East 29<sup>th</sup> Street  
Long Beach, Ca 90806

Phone (562) 595-0661  
Fax (562) 426-7897  
[www.kusterco.com](http://www.kusterco.com)

## **INTRODUCTION**

The Kuster Air Calibration Bath is designed to calibrate KPG, K2, K3, K4 and the AK-1 subsurface pressure instruments. Temperature gages may be checked using the air bath, but calibrating is not recommended. The air bath must be used in conjunction with a dead weight tester to achieve accurate calibration. The air bath consists of an upright calibration chamber, motor, circulation fan, electrical heaters and indicator-controller. All controls are mounted on one panel. The heaters, fan and motor are serviced from floor level. A circulation fan moves air through electric heaters. The heaters are controlled by a thermocouple indicator-controller. The circulation fan and heater are electrically connected so that the bath cannot be damaged by operation of the heater without air circulation

## SPECIFICATIONS

<b>Capacity</b>	KPG	1-1/4" x 73" (32mm x 186mm)
	K2	1" x 39" (25mm x 99mm)
	K3	1-1/4" x 41-1/2" (32mm x 105mm)
	K4	3/4" x 42" (19mm x 107mm) 2-1/4" x 39" (57mm x 99mm)
		(up to three gages may be placed in air bath during calibration)
<b>Power (optional)</b>		230 vac single phase 60 Hz
		220 vac single phase 50 Hz
		230 vac 3 phase 60 Hz
<b>Temperature Range</b>		25°C to 42°C - (75°F to 800°F)
<b>Motor</b>		1/4 horsepower
<b>Weight</b>		227 kg (500 lbs)
<b>Heaters, (3)</b>		2250 watts each
<b>Dimensions (overall)</b>		27-3/4" x 33-1/2" x 94-3/4"
		(704mm x 851mm x 2407mm)

## SPECIFICATIONS

### Controller: Love Model 149

<b>INPUT</b>	Thermocouple, Type J
<b>INPUT IMPEDANCE</b>	Greater than 500,000 ohms
<b>COMMON MODE REFLECTION</b>	Greater than 120 DB @ 240 V.A.C. (60 Hz)
<b>ACCURACY</b>	+/- 0.25% of span or +/- 1° whichever is greater (+/- least significant digit)
<b>REPEATABILITY</b>	+/- 0.1% of span
<b>RESOLUTION</b>	1° or 0.1° dependent upon range.
<b>PROPORTIONAL BAND</b>	Adjustable, 0.5 to 30% of span on time Proportioning model 149
<b>AUTOMATIC RESET (Integral)</b>	Adjustable, off to 15 minutes (off to 0.06 repeats per minute)
<b>AUTOMATIC RATE (Derivative)</b>	Adjustable, off to 3 minutes. On proportioning model 149.
<b>CYCLE RATE</b>	Adjustable, 5 to 50 seconds, in center of band On time proportioning model 149.
<b>SETABILITY</b>	+/- least significant digit.
<b>MAXIMUM THERMOCOUPLE RESISTANCE</b>	300 ohms with rated accuracy.
<b>SUPPLY VOLTAGE</b>	120/208/240 V.A.C., 50/60 Hz by Terminal selection
<b>LINE VOLTAGE STABILITY</b>	+/- 0.2% of span maximum, within 85 to 110% of rated line.
<b>CONTROL RELAY</b>	Plug-in, 10 A (120 V.A.C.), non-inductive. Single pole, double throw contacts.
<b>TRANSFORMER</b>	Plug-in, thermostatically protected.

## **SPECIFICATIONS**

### **Controller: Love Model 149**

#### **FUSES**

Common contacts of relay are internally fused for 10A, with 3 AB250 V. fuses.

#### **AMBIENT TEMPERATRURE RANGE**

2° to 60° C. (35° to 140° F) maximum.

#### **TEMPERATURE STABILITY**

(7 uV./ °F.) maximum.

#### **HUMIDITY CONDITIONS**

0 to 70% R.H. normal operating conditions

#### **THERMOCOUPLE BREAK PROTECTION**

Selectable up-scale or down-scale standard.

# INSTALLATION

## Packing List

- |                    |                                 |
|--------------------|---------------------------------|
| 1. Air Bath        | 4. Manual Drive Unit (optional) |
| 2. Controller      | 5. Air Bath Instruction Manual  |
| 3. Triple Manifold | 6. Manifold Fitting             |

## Installation Instructions

1. Place air bath in an area with a minimum of six inches clearance on all sides. Minimum ceiling distance must be 102 inches. Adequate ventilation is required because heat and fumes may be present during operation. The air bath should not be installed in an area that is subjected to adverse weather conditions.
2. Bolt to floor through four holes located in base.
3. Install temperature controller (shipped separately) by placing controller module in opening located at the top of the electrical panel. Tighten into position with screw located under controller lid. (Fig. 1,H)
4. A qualified electrician must wire the unit. A wiring diagram is located on back of electrical panel face plate. (Dwg. 1)
5. Air bath must be grounded. (Dwg. 1)
6. Initial operation test should be run prior to calibration. (see calibration procedure 7a-7c)
7. The air bath is now ready for operation.

## CALIBRATION PROCEDURE

1. Add fluid to manifold. Fluid must overflow when gage is made up to manifold. Dow Corning Silicone oil #200 or #210H, is recommended. (see accessory sheet)
2. Excess fluid which has spilled or dropped on the manifold or bottom of the bath while preparing the instruments should be carefully cleaned up before turning unit on.
3. Attach gage to calibration manifold. (Fig. 2,A) (manifold adapter subs are required for K2, K4 and AK-1 gages, see accessory sheet)
4. If air bath is equipped with manual drive unit, insert manual drive adapter onto recorder and insert into manual drive unit. (Fig. 2,B; Specific drive adapters are required for all pages. (see accessory sheet)
5. Attach pressure line from dead weight tester to manifold line. (Fig. 2,C)
6. Flex the element and check for leaks by pressuring up the element to the maximum pressure range being calibrated. Release the pressure and allow to stand for 15 to 20 minutes to allow the coil to relax.
7. Turn on and set calibration bath as follows:
  - a) Start bath by pushing main breaker switch to "on" position. (Fig. 1,A)
  - b) Internal temperature will then read out on controller. (Fig. 1,B)
  - c) Calibrating temperature is set by:
    - Step 1 Selection of hi-low range located inside hinged panel. (Fig. 1,C)

## CALIBRATION

- Step 2      Actuate set point switch and hold on S.P.I. (Fig. 1, D)
- Step 3      Depress black knob (Fig. 1,E) and rotate clockwise for raising temperature (counterclockwise for lowering) until desired temperature is indicated.
- Step 4      Releasing both switches will indicate the internal temperature reading,

d) A thermometer well has been provided (Fig. 1,F) to insert a mercury thermometer to check actual temperature in the heated zone against controller indicated readout.

e) The controller adjustment has been factory pre-set, However, a periodic check is recommended.

f) If adjustment is necessary in the field, it can only be accomplished by replacing the thermocouple assembly. (Fig. 1,G)

g) Let stand for 30 to 40 minutes to allow the gage to reach calibration temperature.

8. When the temperature of the calibration bath has stabilized, adjust the recorder by rotating the manual setting knob on the manual drive unit. (Fig. 2,E) Turn counter-clockwise at least one full turn, stopping with the knob indicator toward the front of the calibration bath, facing the operator.
9. Make a minimum of five (5) stops over the pressure range of the element for computer program data points.

For example:

a) 5000 psi element:

Five stops in 1000 psi increments

## CALIBRATION

b) 2100 psi element:

Five stops in 400 psi increments  
plus one 100 psi stop or seven  
stops in 300 psi increments.

10. To obtain the pressure stops (using 5000 psi as an example):

- a) Apply 1000 psi with the dead weight tester.
- b) Move manual setting knob counter-clockwise 1/2 turn,
- c) Increase to 2000 psi with the dead weight tester,
- d) Move manual setting knob clockwise 1/2 turn,
- e) Repeat this procedure until the desired maximum pressure is obtained. In this example, 5000 psi.

11. To release the pressure:

- a) Release 10% of the pressure (in above example, 500 psi).
- b) If knob indicator is facing the operator:
  1. Turn knob 1/4 turn counter-clockwise.
  2. Release all pressure.
  3. Turn knob 1/4 turn counter-clockwise until indicator faces away from the operator
- c) If knob indicator is facing away from the operator:
  1. Turn knob 3/4 turn counter-clockwise,
  2. Release all pressure.
  3. Turn knob 1/4 turn counter-clockwise until indicator faces away from the operator.

12. Recorder is now in position for calibration at second temperature, usually 250°F.

13. Increase the bath temperature to the second calibration temperature and allow the system to stabilize.

## **CALIBRATION**

14. Repeat steps 9 through 11 for calibration at the second temperature.
  
15. This procedure can be repeated at as many temperatures as desired.
  
16. After the final calibration:
  - a) Turn air bath off. Open door and allow to cool.
  - b) When cool, remove gage from manifold.
  - c) Disassemble gage and remove chart.
  
17. Chart is now in proper form to be read for deflections at corresponding pressures. (Refer to chart reader manual for step by step instructions on how to read pressure charts)

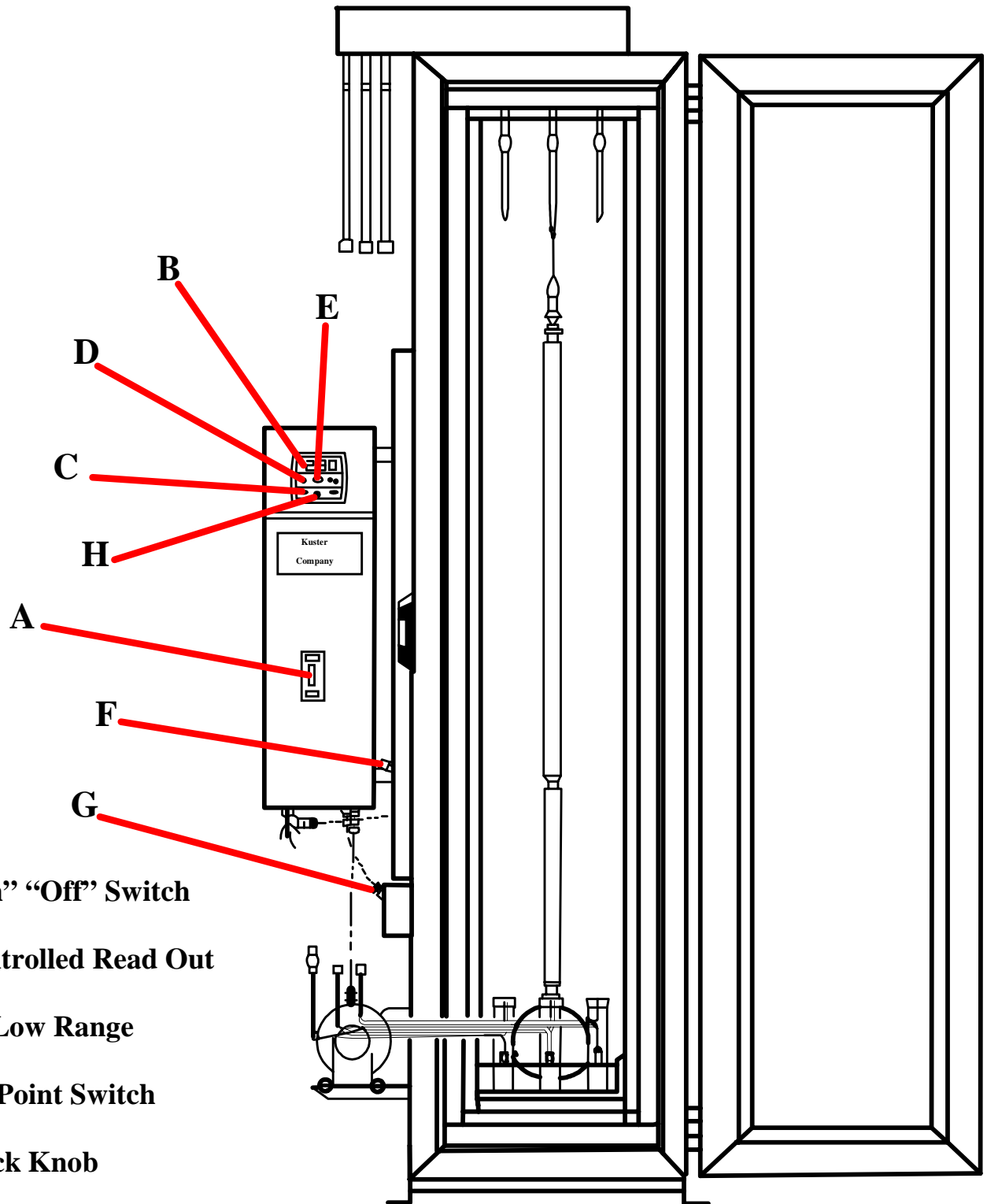

- A. "On" "Off" Switch
- B. Controlled Read Out
- C. Hi-Low Range
- D. Set Point Switch
- E. Black Knob
- F. Thermometer Well
- G. Thermocouple Assembly
- H. Screw

**Figure 1**

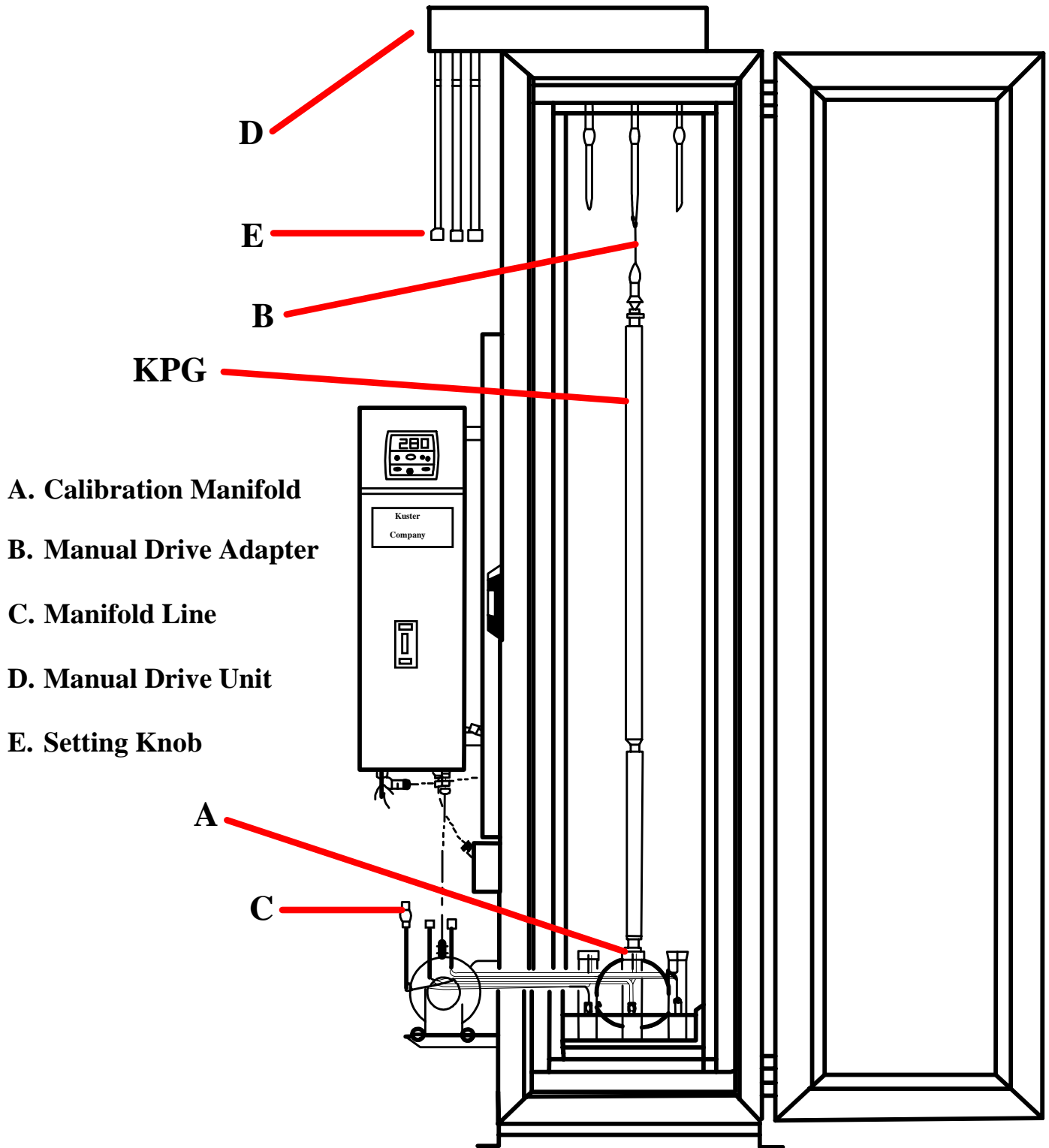

**Figure 2**

## ACCESSORY SHEET

<b><u>Manifold:</u></b>	Triple	P/N 20000-514
<b><u>Manifold Adapter Subs:</u></b>	K2	P/N 288-001
	K4	P/N 488-001
	AK-1	P/N 9507-001
<b><u>Manual Drive Calibration Assembly:</u></b>	KPG	P/N 10325-101 (housing included)
	K2	P/N 10327-101
	K3	P/N 10326-101
	K4	P/N 10327-102
<b><u>Mercury Maximum Registering Thermometer:</u></b>	(300° to 600°F)	P/N 11134-101
<b><u>Silicone Oil #200:</u></b>	(5 gal)	P/N 904-101
<b><u>Silicone Oil #210H:</u></b>	(1 gal)	P/N 901-102

## **AIR BATH MAINTENANCE**

The Kuster Air Bath has been designed to be virtually maintenance free. However, periodic checks should be made as slight adjustments maybe required.

### Check List:

1. Check belt tension on the motor. If adjustment is required, loosen bolts on motor mount and slide motor until belt is tight. Then tighten into place.
2. Check door seal. Make periodic inspections on rope seal to assure proper seal.  
Replace rope seal if worn
3. Lubricate door latch depending on usage. Lubricate rollers and all moving parts located in door latch.
4. Check blower bearings if excess vibration occurs.
5. Keep interior of air bath clean. Excess fluid may lead to fire hazard.

WIRING DIAGRAM  
 240 VAC.  
 60 HZ.  
 3 PHASE  
 AMPS - 17.7-240 V.

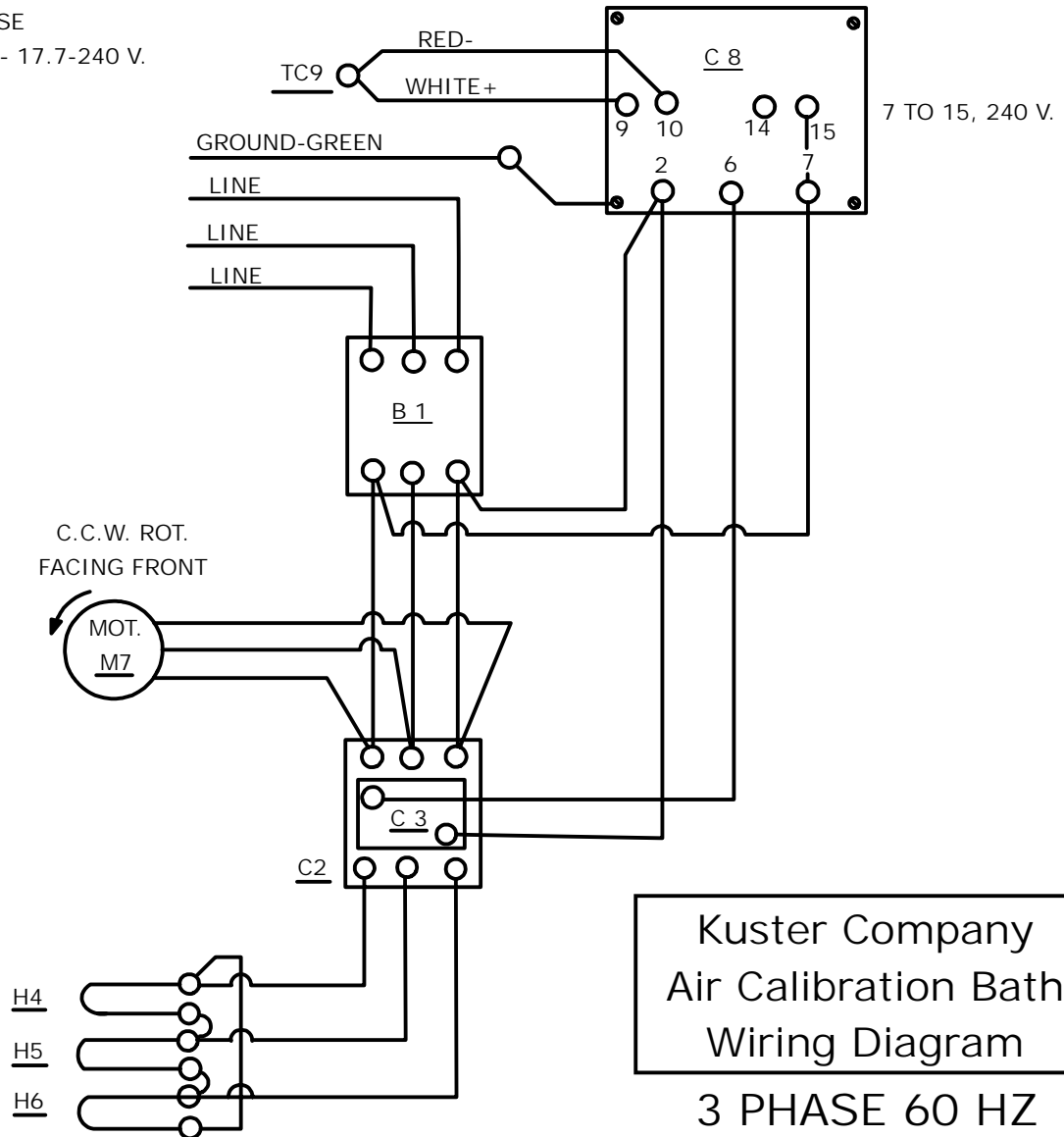

Kuster Company  
 Air Calibration Bath  
 Wiring Diagram

3 PHASE 60 HZ  
 (DWG. 1)

- BI - BREAKER - TEB 132040.
- C2 - MAGNETIC CONTRACTOR - CR205.
- C3 - CONTRACTOR COIL - (15D21G3 240V. - 60 HZ)
- H4, H5, H6 - HEATING ELEMENTS - 16-47499.
- M7 - MOTOR 60HZ. -5K33GG 786
- C8 - CONTROLLER - LOVE, 149 - TYPE J.
- TC9 - THERMOCOUPLER - 20,000-520

WIRING DIAGRAM  
 208-220/240 VAC.  
 50/60 HZ.  
 1 PHASE  
 AMPS - 30.7-240 V.

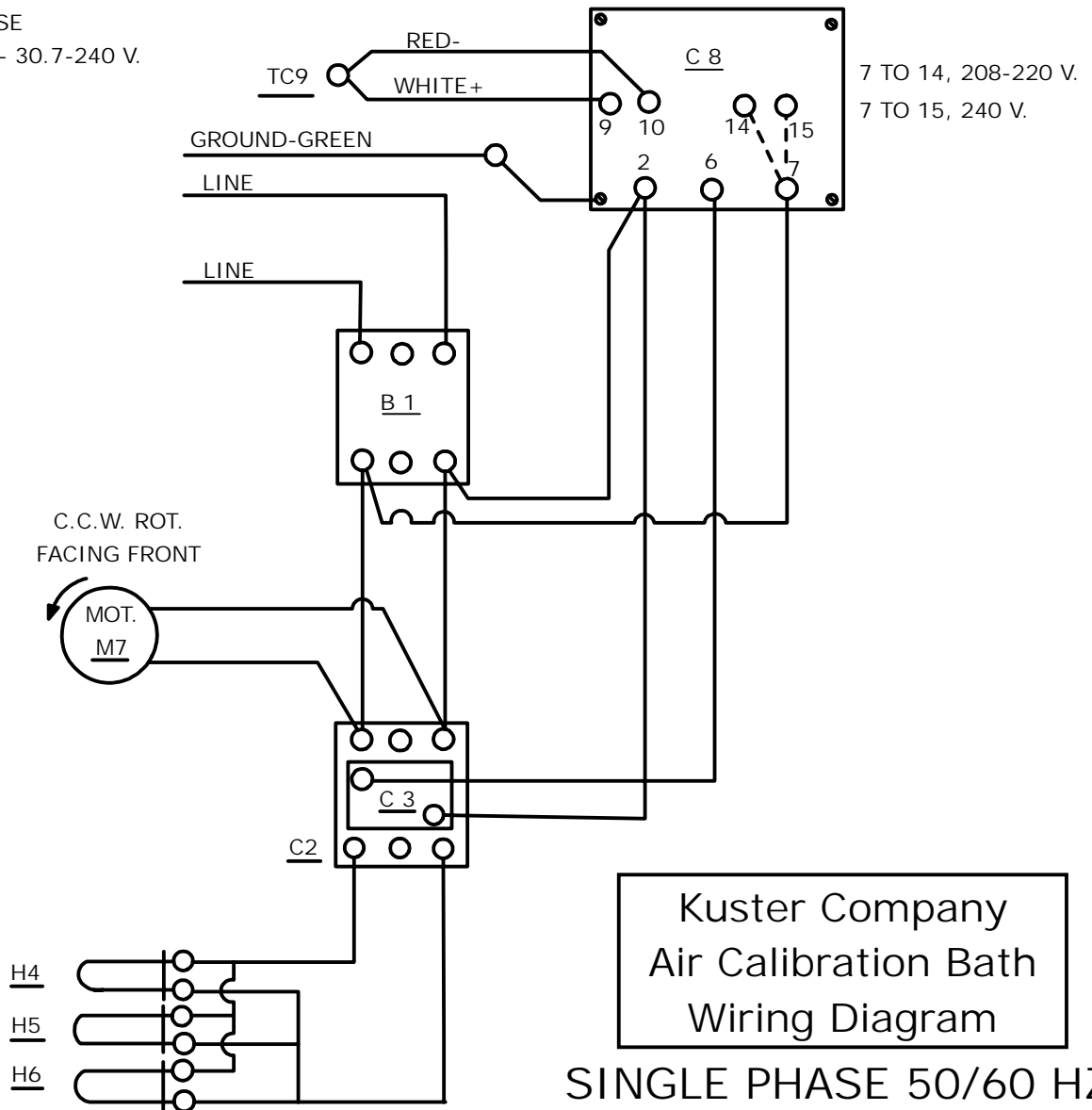

- BI - BREAKER - TEB 132040.
- C2 - MAGNETIC CONTRACTOR - CR205.
- C3 - CONTRACTOR COIL - (15D21G8 220V. - 50 HZ)  
 (230V-60HZ.-15D21G3)
- H4, H5, H6 - HEATING ELEMENTS - 16-47499.
- M7 - MOTOR 60HZ. -5K33FN15T, 50 HZ- 5KC36LNI9T.
- C8 - CONTROLLER - LOVE, 149 - TYPE J.
- TC9 - THERMOCOUPLER - 20,014.

## KPG CHART LOADING PROCEDURE

1. Remove bellows guard. (Fig. 1,b)  
or optional of trap for filter  
or optional labyrinth oil trap assembly

2. Remove wire-line socket. (Fig. 1,a)

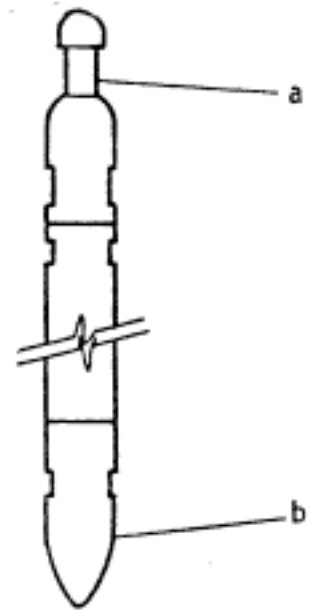

(Fig. 1)

3. Remove clock assembly and recorder unit from outer housing.
4. Loading chart in recorder unit: remove inner housing cover. Move the chart carrier to the top of its travel. Remove the chart carrier by inverting the inner housing and let the chart carrier fall into the hand. (Fig. 2)

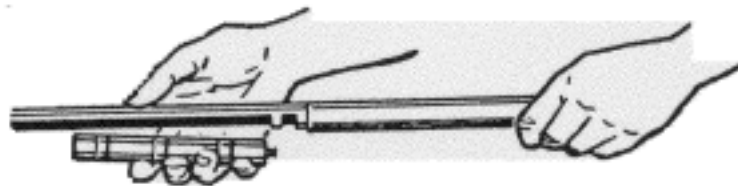

(Fig. 2)

5. Disassemble the inner housing from the pressure element. (Fio. 3) When disassembled, hold the inner housing near the threads and use the inner housing wrench, supplied with the gage. The use of pipe wrenches is not recommended because of possible damage to the inner housing

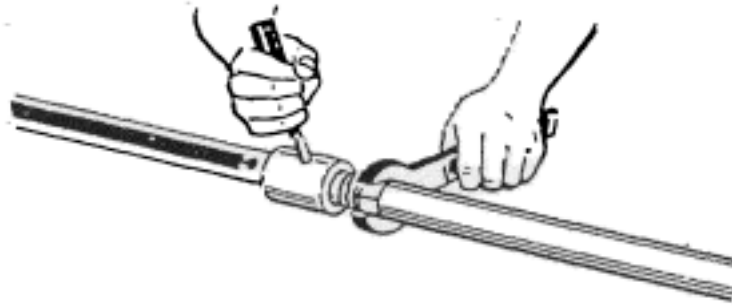

(Fig. 3)

6. Load the chart carrier by wrapping the chart around the chart inserting mandrel. (Fig. 4)



(Fig. 4)

7. With sides parallel to groove, insert chart and mandrel into the chart carrier by engaging the lead edges into the T-shaped guide. (Fig. 5)

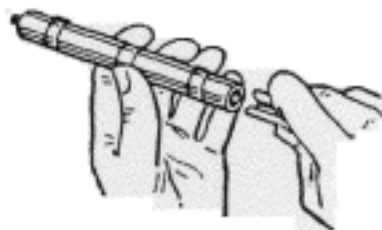

(Fig. 5)

8. Push the chart and mandrel into the carrier. While inserting, a small amount of side motion and back and forth motion is helpful. (Fig. 6) Push the chart all the way in until it projects from the carrier approximately 1/4 inch. Remove the chart inserting mandrel.

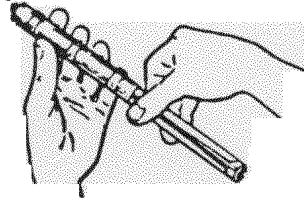

(Fig. 6)

9. Reattach stylus assembly to pressure element. (Fig. 7)

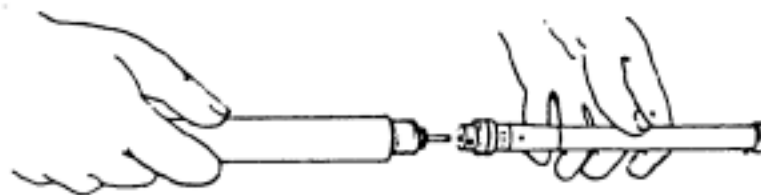

(Fig. 7)

10. The chart carrier is replaced in the inner housing with the fingers; do not handle the chart carrier spring. Move the chart toward the stylus assembly and insert the chart carrier guide bar into the stylus carrier bearing. Move the chart carrier to the lowermost position,
11. Draw base line by placing the stylus lift in the "off" position. Replace the inner housing cover. Place in the "on" position. Move the chart carrier to the uppermost position, thus scribing the base line.
12. (Optional) When using the clock to calibrate, wind the clock by means of the knurled coupler in a counter-clockwise direction. Wind a maximum of 32 turns. Make up the clock in the inner housing.
13. The KPG is now prepared for calibration. (refer to calibration procedures).

## K2 AND K3 LOADING PROCEDURE

1. Remove conical nose piece (Fig. 1,a)  
or optional oil trap  
or optional oil trap (tandem)

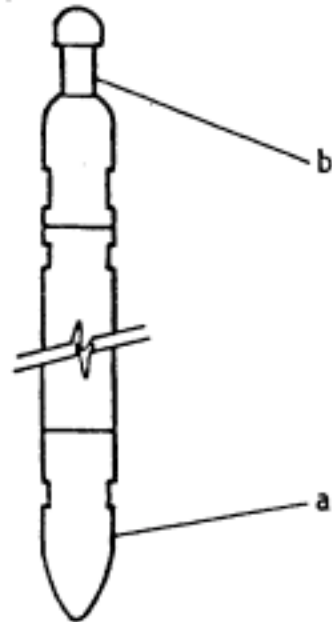

(Fig. 1)

2. Remove wire-line socket. (Fig. 1,b)
3. Remove the clock by unscrewing at the joint indicated by the arrow.  
Use end wrench and the parmalee wrench at the points shown. (Fig. 2)

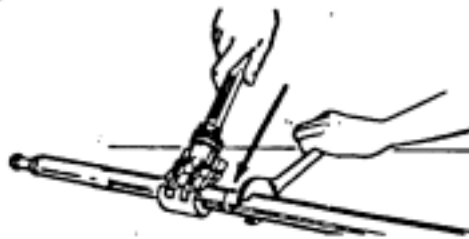

(Fig. 2)

4. When depressing the stylus, place stylus in the "off" position by turning the gear box time converter counter-clockwise. At its extreme limit of travel, the stylus is automatically depressed by the frame plug. (Fig 3)



(Fig. 3)

5. Remove the recorder unit by using the end wrench and the palmalee wrench at the points shown. (Fig. 4)

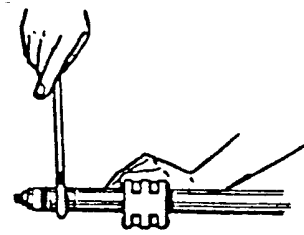

(Fig. 4)

6. Remove the chart cup carefully. The accuracy of the recording is partly based on a concentric chart. (Fig. 5)

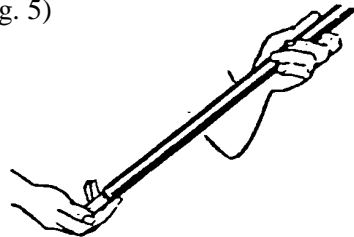

(Fig. 5)

7. To install the chart in the chart cup, place the chart mandrel on the chart with the rounded ends as shown. (Fig. 6) Holding the chart on the chart mandrel, tilt the chart cup, and start the insertion. A slight amount of rotation back and forth may be necessary for a smooth insertion. As the chart approaches bottom, more resistance is encountered. This is caused by the taper of the guide bar forcing the chart outward inside the chart cup. Before the chart has bottomed, slide the chart mandrel further into the chart cup, gathering the chart under the sleeve. Turn the knurled knob clockwise, locking the chart cup, chart and mandrel as one unit. (Fig. 7)



(Fig. 6)



(Fig. 7)

8. Replace the chart cup and chart in the recorder unit. With the arrow of the chart mandrel aligned with the arrow of the pressure unit case, engage the chart cup spline and the ring gear of the bourdon tube. Release the chart mandrel by turning the knurled knob counter-clockwise. Carefully remove the chart mandrel (Fig. 8)



**(Fig. 8)**

9. Install the gear box time converter in the recorder unit. Making sure the slots and pins are aligned, screw the gear box into the recorder unit. Tighten with end wrench. (Fig. 9)



**(Fig. 9)**

10. Install the recorder unit in the pressure unit with the arrow on the recorder unit aligned with the arrow on the pressure unit. Bring the threads together and make up. The arrows should meet in two turns. If not, repeat until the arrows meet. This makes certain the stylus is in the correct position with respect to the chart in the chart cup. (Fig. 10)

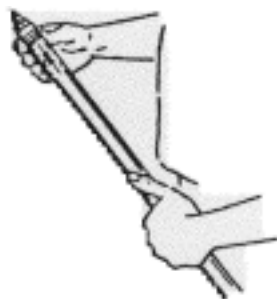

**(Fig. 10)**

11. For gages with bellows, remove the oil trap and fill 1/2 full with clean lubrication oil. Replace the oil trap hand tight and the oil trap plug.
12. Draw a base line for the pressure gage by holding the gage in a vertical position and tap the pressure unit lightly with the hand. Turn the gear box time converter clockwise until it stops. This has drawn the base line and the stylus is in position for calibration. Do not alter the setting.

(Fig. 11)

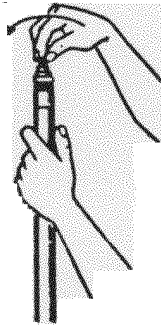

**(Fig. 11)**

13. (Optional) When using the clock to calibrate the K2 and K3, wind the clock with the special socket key provided. Wind counter clockwise to a maximum of 15 turns. Do not overwind. Screw the clock into the recorder unit. Do not force the start of the threads. A slip clutch engages as the clock is made up. (Fig. 12)

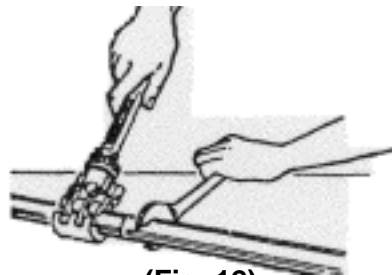

**(Fig. 12)**

14. The K2 or K3 is now prepared for calibration. (refer to calibration procedures)

## K4 CHART LOADING PROCEDURE

1. Remove nose piece. (Fig. 1,a)

2. Remove wire-line socket. (Fig. 1,b)

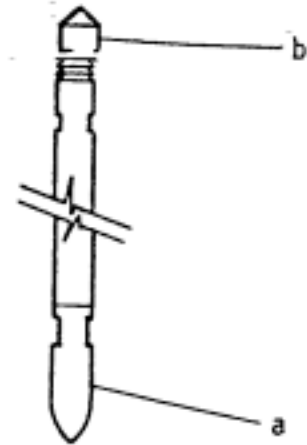

(Fig. 1)

3. Move the stylus to the "off" position by inserting the chart mandrel (Fig. 2) and turn counter-clockwise until the stylus is against the top. The stylus point is automatically depressed and in the "off" position.

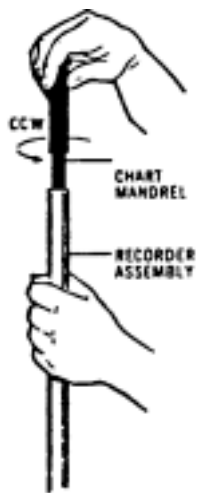

(Fig. 2)

4. Remove the upper housing. Remove the chart tube from the stylus assembly tube. (Fig. 3)

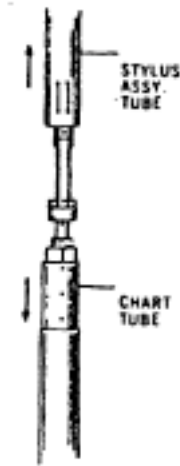

(Fig. 3)

5. Load the chart in the chart tube. Place the chart mandrel on the chart with the rounded ends as shown. (Fig. 4) Holding the chart on the chart mandrel with the right hand, tilt the chart tube with left hand and start the insertion. (Fig. 5) A slight amount of rotation back and forth may be necessary for a smooth insertion. Lock the chart in the chart mandrel by tightening the knurled end. As the chart approaches bottom, more resistance is encountered. (Fig. 6) This is caused by the taper of the guide when forcing the chart outward against the inside of the chart. When the chart has bottomed and projects about 1/8 inch from the top, unlock and remove the chart mandrel.



(Fig. 4)



(Fig. 5)

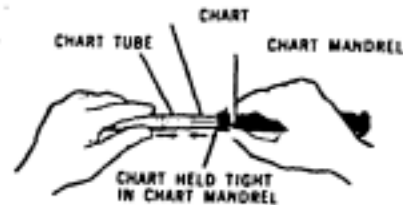

(Fig. 6)

6. Attach the chart tube with the stylus assembly tube. (Fig. 7) No orientation is necessary. Orientation is automatic.

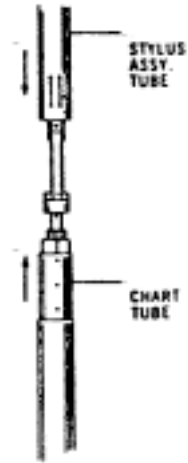

(Fig. 7)

7. Attach the inner housing assembly to the pressure element. (Fig. 8) The spline of the stylus assembly mates with the ring gear of the pressure element. To engage the ring gear and spline, align the pin on the spline with the slot in the ring gear, then assemble the chart tube and stylus assembly tube (inner housing assembly) to the

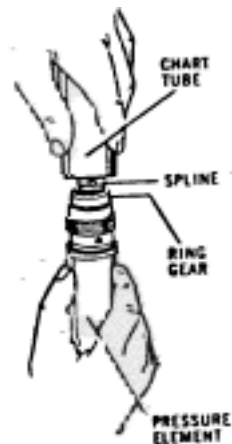

(Fig. 8)

8. Attach the correct gear box to the lead screw tube. Attach the compression spring. (Fig. 9)

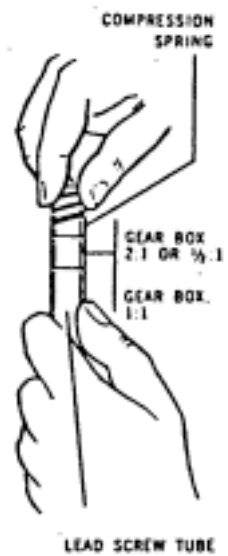

( Fig 9)

9. Replace the upper housing and make up to pressure element. (Fig. 10) Use the tubing wrench near the threaded end. Use the end wrench supplied.



(Fig. 10)

## AK-1 CHART LOADING PROCEDURE

1. Remove top plug. (Fig. 1,a)

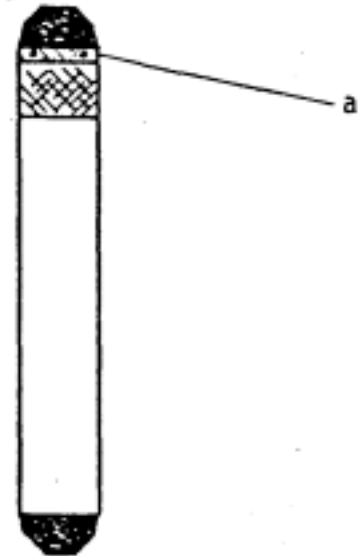

(Fig. 1)

2. Loading chart in the recorder unit, unscrew the base plug from the protective case. Do not break the joint between the base plug and the inner case. Remove the clock retainer and the clock.
3. With the inner case horizontal, remove the case cover by moving the screw away from the cover from the inner case. (Fig. 2)

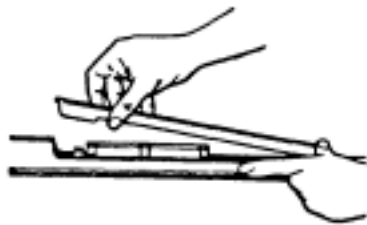

(Fig. 2)

- Slide the chart drum to the bottom of its travel (toward the chart). Remove the chart drum by rotating the inner case and letting the drum fall into the hand. (Fig. 3) Do not lift the chart drum by the chart drum spring.

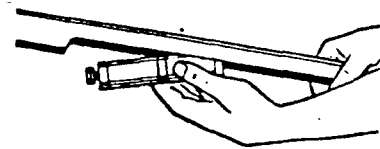

**(Fig. 3)**

- Carefully wrap the chart around the chart mandrel with the coated side inward. The edges of the chart should be parallel with the slot of the chart mandrel. (Fig. 4)



**(Fig. 4)**

- Insert the chart edges into the chart drum guide. Move the chart inward and with a slight rotation until it stops. (Fig. 5) Remove the mandrel carefully. Do not scratch the chart.



**(Fig. 5)**

7. Place the chart drum in the inner case. The groove of the lead screw collar must be engaged with the semi-circular ring partition.
8. With the stylus lifting wire in the "off" position, slide the chart drum over the stylus carrier. Replace the inner case cover. Move the chart drum to the top of the gage, nearest the bourdon tube.
9. Move the stylus lifting wire to the "on" position.
10. Place the inner case assembly in a near vertical position (bourdon tube at the top) while holding the chart drum so that it will not fall. Tap the inner housing lightly, to remove static friction. (Fig. 6)

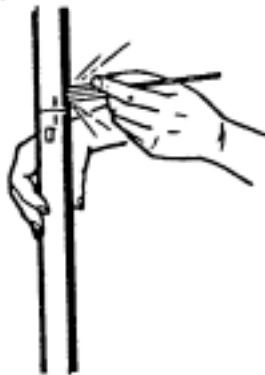

(Fig. 6)

14. The clock must be used when using the air bath to calibrate.
15. Remove the clock retainer and wind the clock counter-clockwise. The clock should be wound a minimum of 17 turns, or until a large resistance is felt.
16. Place the clock in position. Engage the clutch pins in the lead screw. Install the clock retainer with the o-ring and make up hand tight
17. Insert the inner case assembly in the protective case and tighten. Use the base plug wrench and tubing wrench as required.
18. The AK-1 is now prepared for calibration. (refer to calibration procedures)